

LOC	DIST	P	F	ZONE	LTR	DESCRIPTION	DATE	APPRO
G	14				E	REV & REDRAWN PER 0720-0040-93	3-30-93	AMP

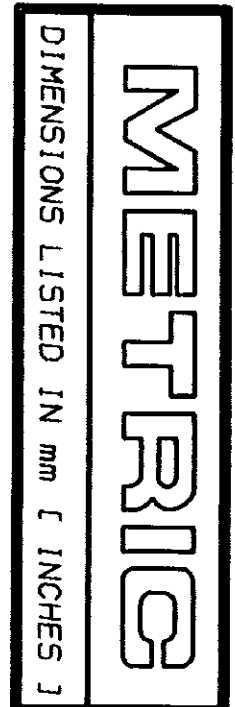

<b>AMP</b> WIRE RANGE	<b>UL</b> E13288 Listed
16-14 AWG SOLID OR STRANDED	16-14 AWG SOLID OR STRANDED
<b>LR7189</b> Certified	MILITARY P/N AND CLASS
16-14 AWG SOLID OR STRANDED	NOT APPLICABLE

△ STAMP AMP 16-14\* APPROX AS SHOWN

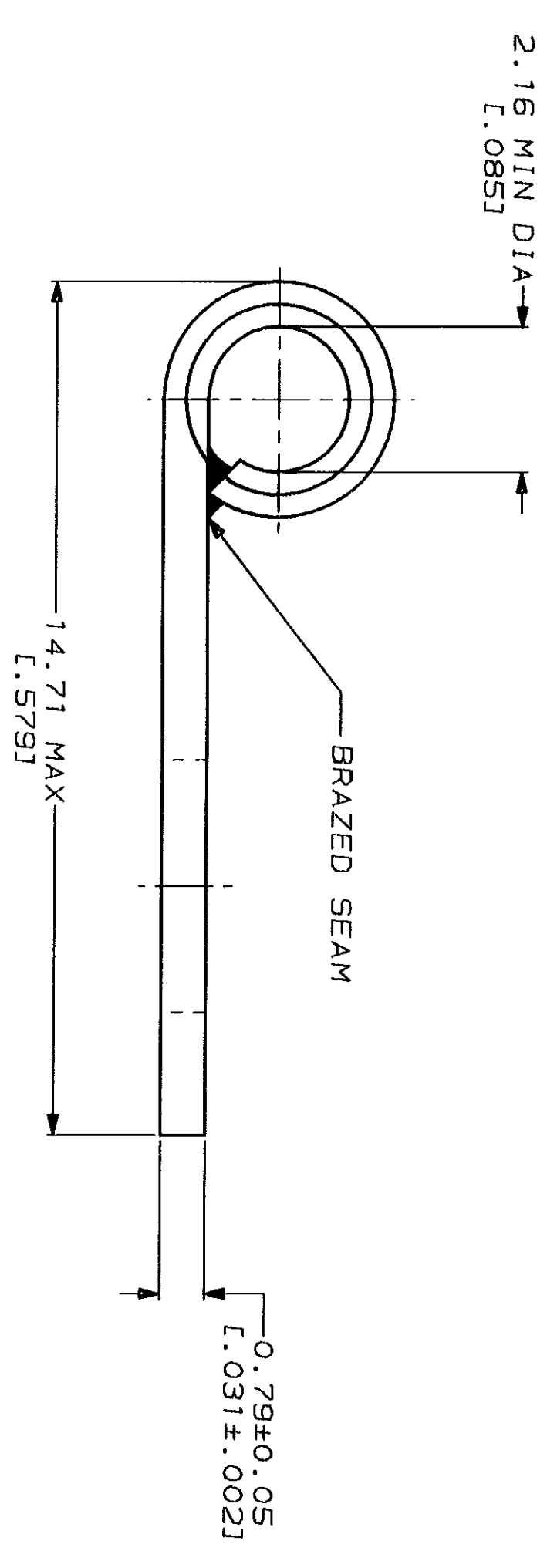
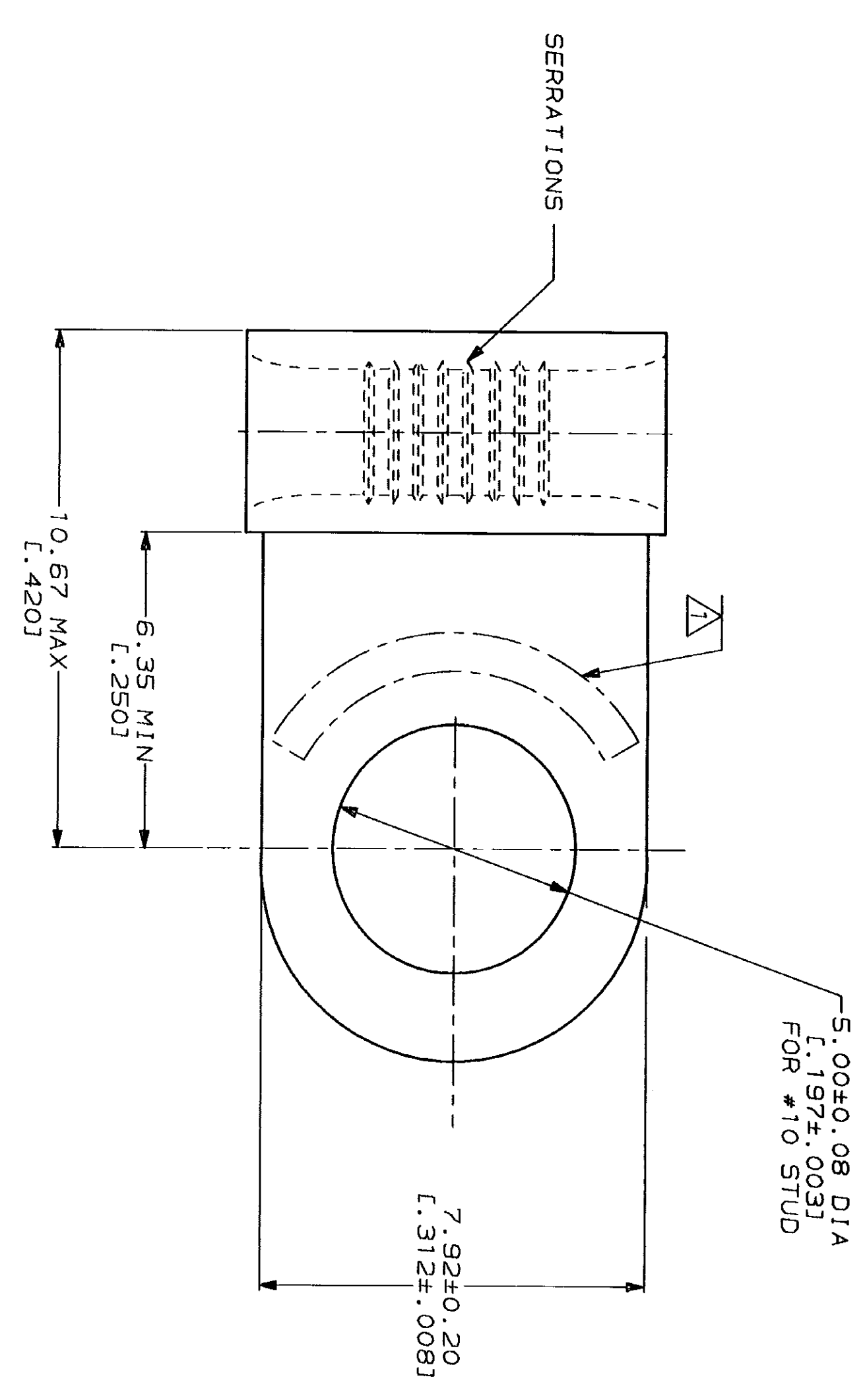

**AMP INCORPORATED**  
**CUSTOMER SERVICE SYSTEMS**

FOR ADDITIONAL PRODUCT INFORMATION OR COPIES OF DRAWINGS AND TECHNICAL DOCUMENTS	PRODUCT INFORMATION CENTER 1-800-522-6752	MAX RECOMMENDED OPERATING TEMPERATURE: 170°C MAX	DO NOT SCALE PRINT. UNLESS SPECIFIED DIMENSIONS IN mm FINISHES - TOLERANCES ON: 1. DEC # - 2. DEC # - 3. DEC # - ANGLES
FOR APPLICATION TOOLING INFORMATION	TOOLING ASSISTANCE CENTER 1-800-722-1111	VOLTAGE RATING: NOT APPLICABLE	MATERIAL COPPER PER ASTM B-152 ANNEALED
FOR ORDER ENTRY	1-800-526-5142	WIRE CROSS SECTIONAL AREA RANGE: 1.04-2.62mm <sup>2</sup> [2,050-5,180] CIR MILS SOLID OR STRANDED	FINISH TIN PLATE 0.00254 [L.000100] MIN THK PER MIL-T-10727

AMP 147-6 REV 3-92	10 SEP 1993	13.23.28	AMP26463	<S128A>DEPT1123>DUG123>U SOLISTRAND>U FLAG
DR 3-30-93 TA BRINKMAN	CHK 3-30-93 DA PATTERSON	APPD 3-30-93 DE MILLER	APPD 3-30-93 JL MECKLEY	PRODUCT SPEC
NAME <b>AMP</b> AMP Incorporated Harrisburg, PA 17105-3608		SIZE CAGE CODE 00779	DRAWING NO 322819	SHEET 1 OF 1

CUSTOMER DRAWING